



REVOLUTION WATER HEATER

VRP PLUS-150 VRP PLUS-199
VRS PLUS-150 VRS PLUS-199

Specification Sheet

VRP / VRS PLUS Model (Tankless Water Heaters)

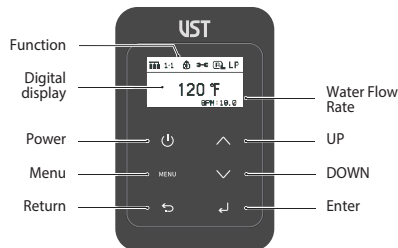
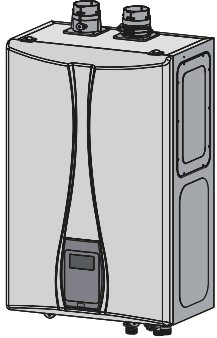

Indoor and Outdoor Venting Options

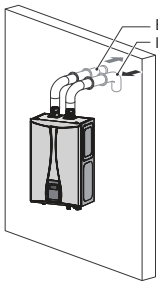

Direct Vent (Indoor)

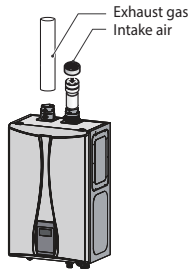

Non-Direct Vent (Indoor)

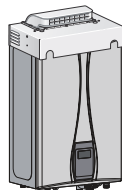

Outdoor Vent

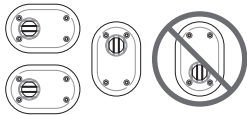

Direct Vent Termination (Indoor)

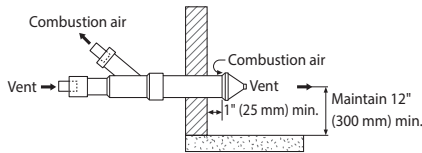

Direct Vent Concentric Termination (Indoor)

Optional accessories



Remote controller (20811825)

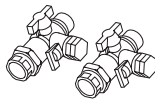

Isolation valve kits (2040172)



Cascade cable (3131289)

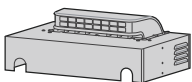

Outdoor Vent Kit (2110546)

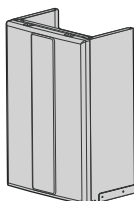

Pipe Cover (2110547)

- Certified design according to ANSI Z21.10.3 – CSA 4.3-2015 standards for both indoor or outdoor installations(with optional Outdoor Vent Kit)
- Compatible with 1/2" gas pipe up to a length of 20 ft* (*see Installation manual for additional information)
- Compatible with 2" PVC vent up to 60ft** and 150 ft** using 3"PVC vent (**with no elbows)
- Gas Input Ranges
VRP/S PLUS 150 - 19,900 to 150,000 BTU/h
VRP/S PLUS 199 - 19,900 to 199,000 BTU/h
- Hot Water Flow Rate Capacity (* based on 35°F temperature rise)
VRP/S PLUS 150 - 8.4 GPM
VRP/S PLUS 199 - 11.2 GPM
- Dual Primary and Secondary Stainless Steel Heat Exchangers for optimum efficiency and durability
- Built-in Control Panel - allows adjustment of temperature setting and displays the operating status and error codes
- VRP PLUS models come included with built-in 0.5 gallon Buffer Tank and Recirculation Pump(UPS 15-58) to provide maximum comfort
- Compatible with Grundfos Comfort valve for maximum comfort and simple installation.
- Temperature Options - available temperature settings for Residential applications range from 98°F up to 140°F with high temperature commercial mode capable of up to 180°F
- Cascade Compatible for up to 8 units per group for increased hot water production
- Easy installation with Cascade Racks & Customized manifolds
- Available with Wi-Fi Control
- On demand recirculation system with VST optional remote control
- Freeze Protection - It has a freeze protection feature that preheats the water heater when its internal temperature falls below 43°F.
- Uniform Energy Factor Ratings for NG and LP units
VRP PLUS-150 / 199 - 0.95 UEF
VRS PLUS-150 / 199 - 0.96 UEF
- Compatible with Natural Gas(NG) and Propane (LPG)***
(***)requires installation of included Field Conversion Kit by a qualified service agency)
- Approved for Installation on Mobile / Manufactured Homes
- Certified by CSA, NSF372, AHRI, AB1953 CA Low Lead, SCAQMD
(Rule 1146.2 type 1 - Complies with 14 ng/J or 20ppm Nox @ 3% O2)
- 15-Year Heat Exchanger and 5-Year Parts Warranty (Residential)
8-Year Heat Exchanger and 3-Year Parts Warranty (Commercial)



Job Name: _____

Location: _____

Engineer: _____

Wholesaler: _____

Contractor: _____

Model No.: _____

Submittes to: _____

Dimensions

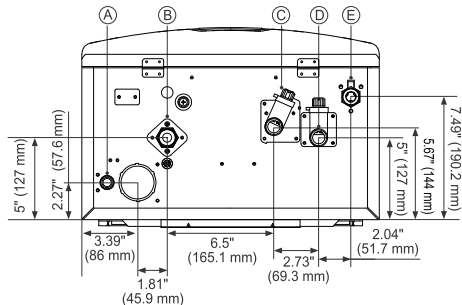
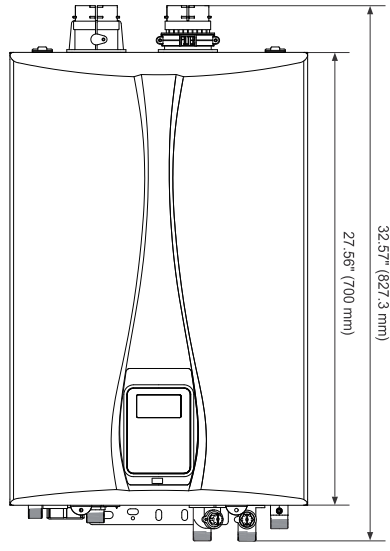
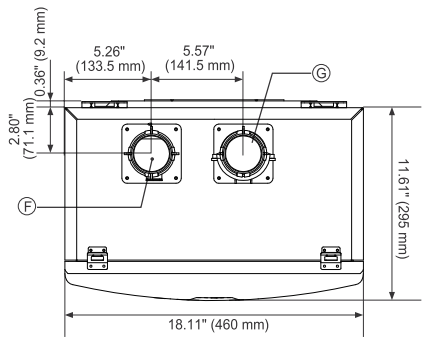

VRP PLUS Model

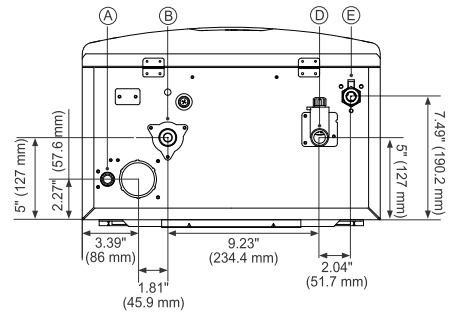

VRS PLUS Model

	Description	Diameter
Ⓐ	Condensate outlet	1/2"
Ⓑ	Hot water outlet	3/4"
Ⓒ	Recirculation inlet	3/4"
Ⓓ	Cold inlet	3/4"
Ⓔ	Gas inlet	3/4"
Ⓕ	Exhaust vent	2"
Ⓖ	Air inlet	2"

Specification

item		VRP PLUS-150	VRS PLUS-150	VRP PLUS-199	VRS PLUS-199
Heat Capacity (Input)	Natural Gas	19,900–150,000 BTU/H		19,900–199,000 BTU/H	
	Propane Gas	19,900–150,000 BTU/H		19,900–199,000 BTU/H	
Energy Factor	Natural Gas	0.95	0.96	0.95	0.96
	Propane Gas	0.95	0.96	0.95	0.96
Flow Rate (DHW)	35°F (19°C) Temp Rise	8.4 GPM (32 LPM)		11.2 GPM (42 LPM)	
	45°F (25°C) Temp Rise	6.5 GPM (25 LPM)		8.7 GPM (33 LPM)	
	77°F (43°C) Temp Rise	3.8 GPM (14 LPM)		5.1 GPM (19 LPM)	
Dimensions (W x D x H)		18.1" x 11.6" x 27.6" (460 mm x 295 mm x 700 mm)			
Weight		75 lbs (34 kg)	67 lbs (30 kg)	75 lbs (34 kg)	67 lbs (30 kg)
Installation Type		Indoor/Outdoor wall-hung			
Venting Type		Forced draft direct vent			
Ignition		Electronic ignition			
Water Pressure		15–150 psi			
Natural Gas Supply Pressure		3.5"–10.5" WC			
Propane Gas Supply Pressure		8"–13" WC			
Natural Gas Manifold Pressure (Min. – Max.)		0.01" WC – –0.35" WC		0.01" WC – –0.59" WC	
Propane Gas Manifold Pressure (Min. – Max.)		0.01" WC – –0.30" WC		0.01" WC – –0.56" WC	
Minimum Flow Rate		0.1 GPM (0.4 LPM) for VRP models / 0.5 GPM (1.9 LPM) for VRS models			
Connection Sizes	Cold Water Inlet	3/4" NPT			
	Hot Water Outlet	3/4" NPT			
	Recirculation Water Inlet	3/4" NPT (Only VRP models)			
	Gas Inlet	3/4" NPT			
Power Supply	Main Supply	120V AC, 60 Hz / use less than 5 AMP			
	Primary Heat Exchanger	Stainless steel			
Materials	Secondary Heat Exchanger	Stainless steel			
	Exhaust	2" or 3" PVC, CPVC, Polypropylene 2" or 3" Special gas vent type BH (Class II, A/B/C)			
Venting	Intake	2" or 3" PVC, CPVC, Polypropylene 2" or 3" Special gas vent type BH (Class II, A/B/C)			
	Vent Clearances	0" to combustibles			
	Safety Devices	Flame rod, APS, Over heat preventer, Exhaust temperature high limit sensor, Power surge fuse			
Power Consumption		135 W	75 W	165 W	105 W

Gas-fired, tankless, condensing, wall-mounted water heater(s) shall be direct vent VRP/S PLUS models as manufactured by VESTA.DS, Inc. and are certified by CSA Group to the latest edition of ANSI standard Z21.10.3/ CSA 4.3. Water heater(s) shall have a 15-year limited Heat Exchanger warranty and 5-year limited Parts warranty (8 year Heat Exchanger and 3-year Parts for Commercial use) per VESTA Limited Warranty. Unit(s) shall be designed to burn natural gas and can be for use with propane when a Field Conversion Kit is installed. Water heater(s) shall have a nominal flow rate capacity of _____ GPM/GPH at _____ °F rise with rated input of _____ BTU/hr. Water heater(s) shall be vented with 2" PVC/CPVC vent pipe at a distance not to exceed 60' (or equivalent) with each elbow equal to 8' of pipe length or 3"PVC/CPVC vent pipe at a distance of 150'(or equivalent) with each elbow equal to 5' of pipe length. Water heater(s) is rated for 150 PSI working water pressure and 300 PSI test pressure. Gas supply pressure shall be 3.5" to 10.5" WC for natural gas and 8.0" to 13.0" WC for propane. Unit(s) shall have a steel case, dual stainless steel heat exchangers, eco premixed burner, negative pressure gas valve, dual venturi, 3/4" inlet gas connection, 3/4" brass inlet/outlet water connections, water holding capacity of 0.9 gallons for the VRS PLUS models, 1.2 gallon for the VRP model, and a condensate collector. The VRS model weights 67 lbs, the VRP PLUS model weights 75 lbs. Unit(s) shall include features such as an adjustment for installations at high elevation, temperature lockout, and temperature options from 98-140°F in 2°F intervals. The unit(s) shall include additional temperature options of 140-180°F in 10°F intervals for high temperature commercial applications. All VRP PLUS models shall include an internal recirculation pump and 0.5 gallon buffer tank. The water heater(s) shall be controlled by an internal circuit board that monitors the inlet and outlet temperatures with installed thermistors, sensing and controlling flow rate to set point temperature with air-fuel ratio controls in order to maintain thermal combustion efficiency. Unit(s) shall include safety features such as flame sensor system, high limit sensors, overheat prevention device, freeze protection mode, and fan motor rotation detector. Cascade systems that require 2 to 8 units shall be installed by connecting the units using cable-only connections. The water heater(s) is listed by SCAQMD rule 1146.2 (Type1) for Low Nox that complies with 14ng/J or 20ppm Nox requirements @ 3% O2.

* VESTA.DS reserves the right to change specifications at any time without prior notice.